

Tucson Amateur Packet Radio
 8987-309 E. Tanque Verde Rd #337
 Tucson, Arizona ☎ 85749-9399
 Office: (817) 383-0000 ☎ Fax: (817) 566-2544
 Non-Profit Research and Development Corporation

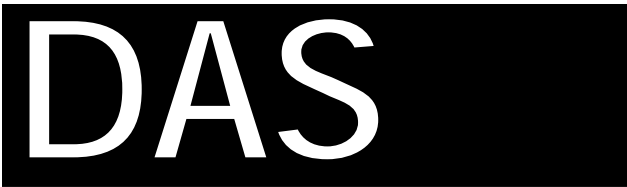

DAS Assembly Manual

This document was written January 1996. ©1996 Tucson Amateur Packet Radio Corp.

Reproduction or translation of any part of this work beyond that permitted by sections 107 or 108 of the 1976 United States Copyright Act (or its legal successor) without the express written permission of Tucson Amateur Packet Radio Corporation is unlawful except as noted below. Requests for permission to copy or for further information should be addressed to Tucson Amateur Packet Radio Corporation. Except as noted above, permission is hereby granted to any non-profit group or individual to reproduce any portion of

this document provided that: the reproduction is not sold for profit; the intent of the reproduction is to further disseminate information on Amateur Packet Radio; the reproduction is not used for advertising or otherwise promoting any specific commercial product and/or service; full credit is given to Tucson Amateur Packet Radio Corporation (including address) as the original source of information; and Tucson Amateur Packet Radio Corporation is notified in writing of the reproduction.

The information contained in this document has been carefully checked and is believed to be entirely reliable. However, no responsibility is assumed for inaccuracies. Tucson Amateur Packet Radio Corporation (TAPR) reserves the right to make changes in any products to improve reliability, function or design without obligation to purchasers of previous equipment. TAPR does not assume any liability arising out of the application or use of any product or circuit described herein; neither does it convey license under its patent rights or the rights of others.

Table of Contents

INTRODUCTION	1
PARTS LIST.....	2
DAS Board Layout	3
CONSTRUCTION.....	3
TB1 and TB2	3
Diode.....	3
Capacitors	3
Test Points	4
Test	4
Voltage Regulator	4
IC Sockets	4
Capacitors	5
Relay.....	5
Resistors	5
Diodes	5
Capacitors	5
Remaining Components.....	6
Shunt Loops.....	6
Optional Parts	6
TESTING	6
IN CASE OF DIFFICULTY	6
SCHEMATIC	7

INTRODUCTION

DAS (DTMF Accessory Squelch) acts like a switch connected in series between the speaker output of your VHF or UHF transceiver and an external speaker. DAS will monitor a radio channel for you, with the speaker switch open so the speaker remains silent, until someone sends one of the DTMF sequences you have selected. When DAS hears your your personal Touch-Tone ID sequence on the radio channel it will light a LED, sound an buzzer and close the series speaker switch so that you can hear the audio of the calling station. An introductory discussion of DAS was published in QST, December, 1995, pages 25-31.

Look for files on:

[ftp.tapr.org/tapr/das](ftp://ftp.tapr.org/tapr/das)

www.tapr.org

- or -

ARRL BBS: +1 860 594 0306, 8-N-1,

look in the FILES area, search on DAS

DAS technical and user support group:

send Internet e-mail to: 'listserv@tapr.org'

in the message body type

subscribe das YourName

PARTS LIST

Please keep in mind that this is a partial kit. The partial kit includes the PC board and almost all parts that mount on the PC board. We do NOT include LEDs, Connectors, Switches, Cabinet, etc. These can be found in the optional parts section. You can get most of these parts from catalogers, Radio Shack or your junk box.

Sort the parts into egg cartons, muffin tins, or other containers as you inventory them. This will aid you in building.

Check off the part in the () space provided as you locate and verify it against this list.

NOTE: Shaded Parts are option only. These parts should be ignored.

Resistors, 1/4 watt, 5%

- () 1 560 ohm (green-blue-black-gold)
- () 3 1k ohm (brown-black-red-gold)
- () 9 10k ohm (brown-black-orange-gold)
- () 1 33k ohm (orange-orange-orange-gold)
- () 2 330k ohm (orange-orange-yellow-gold)

- () 1 1M Single Turn Pot (Bourns 3362P-105)

Capacitors

Capacitors may be marked in various ways. The typical markings are given but may vary. Find all that match the typical markings given and the remaining ones, if any, should become apparent by elimination.

Mylar or Monolithic

- () 10 0.1 uF (104)
- () 2 33 pF (330)
- () 1 100pf (101)

Electrolytic

Electrolytic (or tantalum) capacitors are polarized.

- () 1 10 uF Radial Lead
- () 1 100 uF Radial Lead
- () 1 470 uF Radial Lead

Diode

- () 6 1N4148 Silicon Diode
- () 1 1N4002 Silicon Diode

Integrated Circuits

Integrated Circuits come from various manufacturers and may have differing prefixes and/or suffixes. For example, if the part is listed as a 74LS00, it may be marked SN74LS00N or MC74LS00P or DM74LS00N or F74LS00P or some other variation. The key is that the sequence 74LS00 appears in the part number. A four-digit number, such as 8834, indicates the year and week of manufacture and should not be confused with the part number.

NOTE: Do not handle the ICs at this time! Carefully remove the black foam carrier with ICs from the bag and verify the ICs against this list. Then return the foam with the ICs to the bag. Do not touch the ICs!

- () 1 S87C751-1F24 Programmed
- () 1 PCF8582
- () 1 MT8870D
- () 1 UDN2595A

Transistors

- () 1 2N3904 Transistor 2N3904

Sockets

- () 2 18-pin DIP Socket
- () 1 8-pin DIP Socket
- () 1 24-pin .3" DIP Socket

Miscellaneous

- () 1 Printed Circuit Board, DAS
- () 1 Assembly Manual, DAS

- () 1 3.58 MHz Crystal
- () 1 LM78L05 TO-92 Voltage Regulator
- () 1 SPDT Relay Omron G5V-1-DC12
- () 10 Dual Screw Terminal Blocks

Parts Not Supplied

- () 1 SPDT Relay Omron G5V-1-DC12
- () 1 Red LED
- () 1 Yellow LED
- () 2 Green LED
- () 1 2.1mm coax jack Mouser 163-4304
- () 5 3.5mm mono jack Mouser 16PJ137
- () 1 3.5mm stereo jack Mouser 161-3402
- () 4 270 ohm
- () 2 SPST Toggle switch
- () 1 SPST mom switch
- () 5 2 pin header Molex

DAS Board Layout

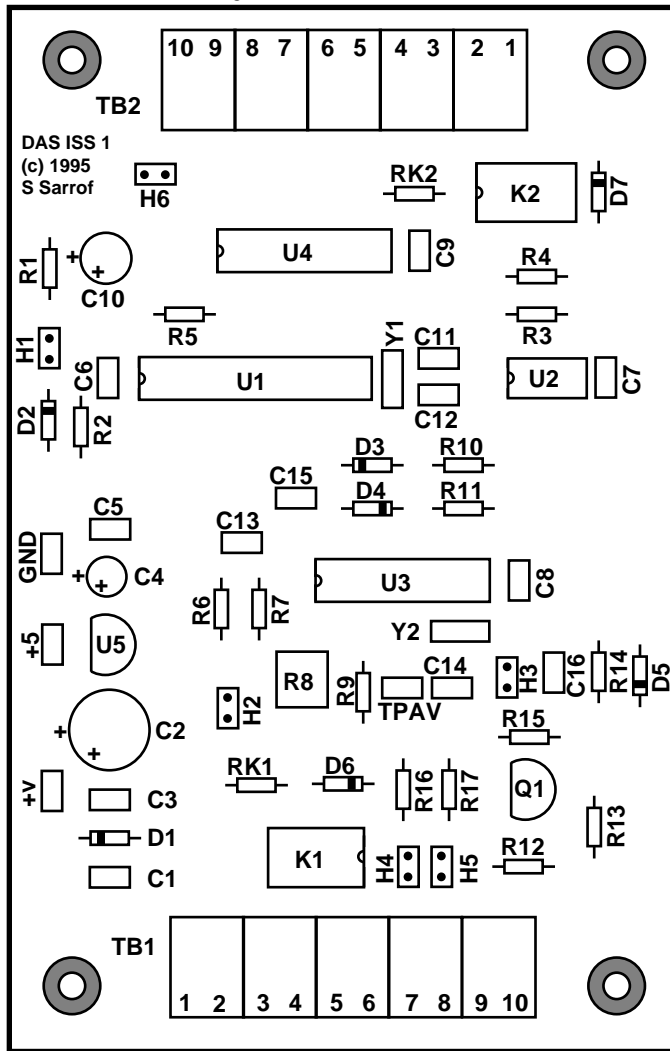

CONSTRUCTION

You are now ready to begin construction of the DAS kit. Use a temperature-controlled, fine-tipped soldering iron and good quality 60/40 or 63/37 rosin-core solder for construction. Follow standard construction practices when building the unit.

In addition to the soldering iron and solder, you will need small flush or semi-flush cutting pliers and small-tipped long nosed pliers. A magnifying glass may prove helpful to identify the values of the small components.

Pay careful attention to the directions that follow. Keep the tip of your soldering iron bright and clean, wiping it frequently on a wet rag or sponge. Make solder joints carefully, but swiftly. Prolonged heat on a PC board pad can be as disastrous as too much heat, and ruining this PC board can be expensive! Two to three seconds should be enough time to apply heat to any joint.

TB1 and TB2 Terminal Blocks

Assemble TB1 and TB2. To do this, note the flange and groove on the the screw terminals. Slide one terminal block flange onto the groove of another block.

Do this **four** times to create a terminal block of 10 terminals. Do this with the remaining screw terminals to create a second block of 10 terminals.

Install TB1 on the PC board. Ensure that the openings on the side of the block for the wires face the edge of the PC board. Solder TB1 onto the PC board.

Install TB2 on the PC board. Ensure that the openings on the side of the block for the wires face the edge of the PC board. Solder TB2 onto the PC board.

Now check your work. All leads should be soldered. There should be no solder bridges or cold solder connections.

() OK so far.

Diode

Diodes are polarized, with the cathode end being banded. Observe polarity when installing the following diode. Leads are at a 0.5" spacing.

() D1 1N4002

() Solder and clip the leads (2 total)

Capacitors

NOTE: All capacitors should be mounted as nearly flush to the board surface as practical without stressing the leads.

() Save the leads from the capacitors. They will be used in a following step.

() C1 0.1 uF (104)

() C3 0.1 uF (104)

() C5 0.1 uF (104)

() Solder and clip the leads (6 total)

The following capacitors are polarized. The positive (+) lead should go in the square pad. Electrolytic capacitors (tubular metal cans with the leads coming out of one end) have the negative lead marked with a bold black band; tantalum capacitors (teardrop-shaped epoxy-covered blobs) have the positive lead marked with hard-to-read little plus (+) signs.

- C2 470uf / 25V
- C4 10uf / 25V

- Solder and clip the leads (4 total)

Now check your work. All leads should be soldered. There should be no solder bridges or cold solder connections.

- OK so far.

Test Points

- Take four of the resistor leads and bend them into loops around a form that is between 1/8 and 3/16 (use a drill bit or small screw driver).

This will form a test point so you don't want the loop to lie flat on the PC board. You want it to stick up a bit so that a clip lead can be attached to the loop. See the graphic below -- it shows a test point as viewed from the side of the board.



- Solder a test loop at GND.
- Solder a test loop at: +5
- Solder a test loop at: +V
- Solder a test loop at: TPAV.

Voltage Regulator

Install the voltage regulator U5. Ensure that the body of U5 matches the silkscreen legend on the PC board.

- 1 78L05 Voltage Regulator
- Solder and clip the leads (3 total)

IC Sockets

NOTE: If any socket pins are bent, carefully straighten them with a pair of long-nose pliers before assembly. Some types of IC sockets have crimps in the pins to hold them in place when automatic wave-

soldering is performed. These sockets may be tricky to install if you are not familiar with them. If your kit contains these sockets, you may want to straighten the pins before attempting to insert them into the PC board.

When installing IC sockets, double check to ensure that the socket is seated properly against the board with the notch, beveled corner or "1" towards the silkscreened reference (U1, U2, etc.). Be sure that all IC socket pins are showing on the solder side of the board. Next, tack-solder two diagonally opposite corners first (such as pins 1 and 8 on a 14-pin socket).

Then solder the remaining pins of that socket before proceeding to the next one. If you find a socket is difficult to install, remove it and double-check for a bent pin.

NOTE: Take care now to avoid solder bridges!

Install the following IC sockets.

- U1 24-pin .3 DIP Socket
- U2 8-pin .3 DIP Socket
- U3 18-pin .3 DIP Socket
- U4 18-pin .3 DIP Socket

Now check your work. All leads should be soldered. There should be no solder bridges (a blob of solder that shorts two adjacent soldered connections) or cold (gray and/or grainy looking) solder connections. You should have no IC sockets remaining.

- OK so far.

Test

- Apply 12 VDC to TB1-1 (gnd) and TB1-2 (+12).
- Current flow should be less than 1 mA.
- Connect a volt meter to TB1-1 (gnd) and be prepared to probe various points on the PC board with the positive lead.
- Measure the voltage at TP+V (i.e. Test Point +V), it should be between 11 and 13 VDC.
- Measure the voltage at TP-GND, it should be less than +/- 0.1 VDC.
- Measure the voltage at TP+5, it should be between 4.5 and 5.5 VDC.

- () Check the voltage at U1 pin 24 (+5v),
- () U2 pin 8 (+5v),
- () U3 pin 18 (+5),
- () U4 pin 9 (+5v).

- () Remove power and continue assembly.

NOTE: If you have a problem obtaining these results please refer to the IN CASE OF DIFFICULTY section at the end of this manual.

Capacitors

NOTE: All capacitors should be mounted as nearly flush to the board surface as practical without stressing the leads.

- () C6 0.1 uF (104)
- () C7 0.1 uF (104)
- () C8 0.1 uF (104)
- () C9 0.1 uF (104)

- () Solder and clip the leads (8 total)

Relay

NOTE: When installing the relay, double check to ensure that it is seated properly against the board with the notch silkscreened reference. Tack-solder two diagonally opposite corners first, then solder the remaining pins of that socket.

- () K1 SPST Relay

Resistors

Resistors lie flat on the PC board and have a lead spacing of 0.4". You may wish to use a lead bending jig to preform the resistor leads for neatest appearance.

WARNING! Be careful when clipping leads, as they have a tendency to fly towards your eyes! Take appropriate precautions (grasp leads and wear eye protection).

- () Save the leads from the resistors. They will be used in a following step.

Install the following 5% resistors:

- () R1 1k ohm (brown-black-red-gold)
- () R2 10k ohm (brown-black-orange-gold)

- () Solder and clip the leads (4 total)

- () R3 10k ohm (brown-black-orange-gold)
- () R4 10k ohm (brown-black-orange-gold)
- () R5 10k ohm (brown-black-orange-gold)

- () Solder and clip the leads (6 total)

- () R6 560 ohm (green-blue-black-gold)
- () R7 10k ohm (brown-black-orange-gold)
- () R9 10k ohm (brown-black-orange-gold)

- () Solder and clip the leads (6 total)

- () R10 330k ohm (orange-orange-yellow-gold)
- () R11 330k ohm (orange-orange-yellow-gold)

- () Solder and clip the leads (4 total)

- () R12 10k ohm (brown-black-orange-gold)
- () R13 33k ohm (orange-orange-orange-gold)
- () R14 10k ohm (brown-black-orange-gold)
- () R15 10k ohm (brown-black-orange-gold)

- () Solder and clip the leads (8 total)

- () R16 1k ohm (brown-black-red-gold)
- () R17 1k ohm (brown-black-red-gold)

- () Solder and clip the leads (4 total)

- () R8 1Meg ohm Single Turn Pot

- () Solder R8 Pot

Now check your work. All leads should be soldered. There should be no solder bridges or cold solder connections. You should have no resistors.

- () OK so far.

Diodes

Observe polarity when installing the following diodes.

- () D3 1N4148
- () D4 1N4148
- () D5 1N4148
- () D6 1N4148
- () D7 1N4148

- () Solder and clip the leads (10 total)

Capacitors

NOTE: All capacitors should be mounted as nearly flush to the board surface as practical without stressing the leads.

- () C11 33pf
- () C12 33pf

- () Solder and clip the leads (4 total)

- () C13 0.1 uF (104)
- () C14 100pf (101)
- () C15 0.1 uF (104)
- () C16 0.1 uF (104)

() Solder and clip the leads (8 total)

The following capacitor is polarized. The positive (+) lead should go in the square pad.

- () C10 100uf / 25V

() Solder and clip the leads (2 total)

Now check your work. All leads should be soldered. There should be no solder bridges or cold solder connections. You should have no diodes or capacitors remaining.

() OK so far.

Remaining Components

NOTE: Transistors are polarized components. Match the body of the transistor with the silkscreened outline and carefully bend the transistor leads to match the hole pattern in the PC board. The bottom of the body of the transistor should be not more than 1/4" above the PC board.

- () Q1 2N3904

() Solder and clip the leads (6 total)

Install the crystal.

- () Y1 3.58 MHz Crystal

() Solder and clip the leads (2 total)

Shunt Loop

- () Take two of the resistor leads and bend them into loops around a form that is between 1/8 and 3/16 (use a drill bit or small screw driver).

This will form a shunt. See the graphic above.

- () Solder a shunt loop at H2.
- () Solder a shunt loop at H3.

**This completes the assembly.
Congratulate yourself!**

- () You should have components in all sites **EXCEPT** H1, H4, H5, H6, K2, RK1, RK2, Y2.

Optional Parts

- H1 is not needed except in exceptional circumstances.
- H4, H5 and H6 are not needed unless you are using OT0 and OT1 for some special remote control application not yet defined.
- K2 is not needed unless you have a remote external alarm (like to drive the horn relay in a car). If you need an external alarm you can get this relay from DigiKey (see parts list).
- Resistors RK1 and RK2 provide for the option of using 5 volt relays with the proper value of dropping resistor. RK1 and RK2 are shorted on the bottom side of the PC board.
- Add your own external connectors, LEDs and housing, as meets your needs and then continue testing as described in the "Initial Testing" section of the QST article.

Test Section

Refer to the QST article for details on testing as well as configuring your decoder. Refer to the DAS Configuration Users Guide for information about advanced configuration.

In Case of Difficulty

As with most manual electronic assembly and manufacture processes, 95% of the problems are physical in nature (and not bad components). They can usually be located with a good visual inspection.

If you have a problem check all installed components to ensure that they are the correct value, placed in the correct holes and that they are installed with the correct polarity. The silk screen is ambiguous in one or two places with regard to electrolytic polarity. Also look for solder bridges and cold solder joints.

If you find that the microcomputer does not seem to operate properly, check for a 3.58 MHz clock signal on pin 10 of U1. If you don't see it, remove C11 and C12 and measure their values. In some cases capacitors marked as "330" may be 33 pF or 330 pF. The crystal oscillator will work if C11 and C12 are between 20 and 40 pF. The crystal oscillator in most cases will not function if C11 and/or C12 are more than 300 pF.

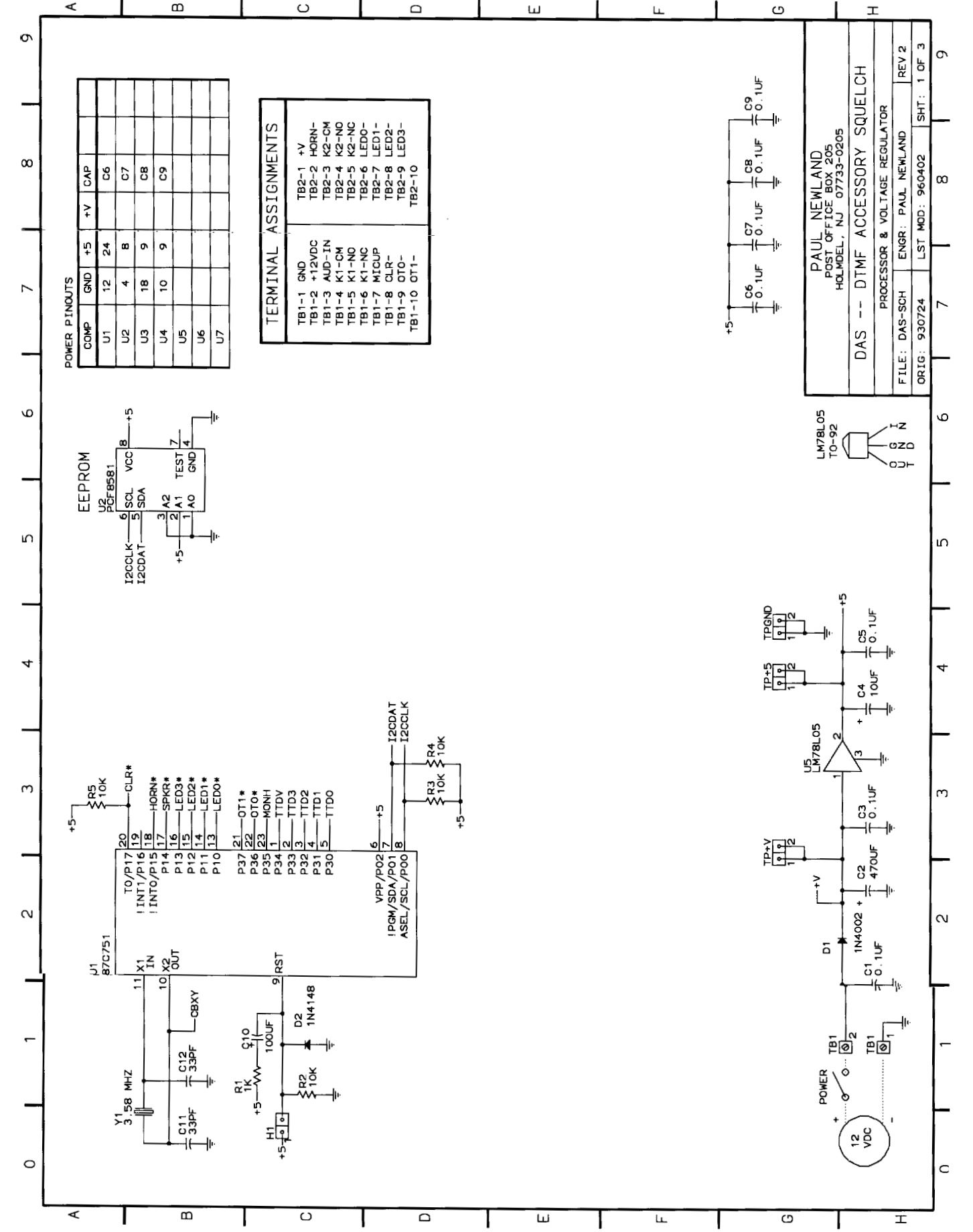

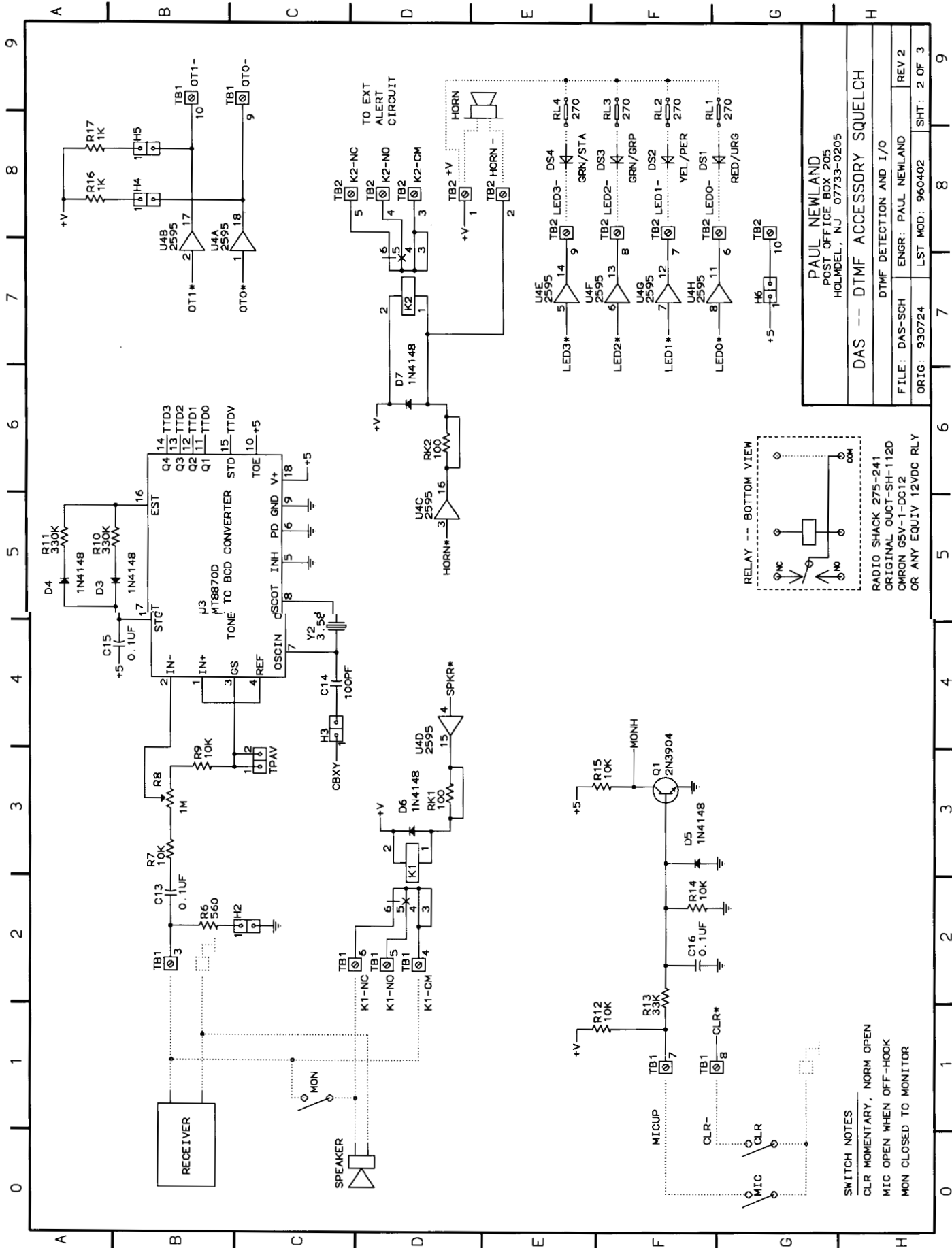

PAUL NEWLAND
 POST OFFICE BOX 205
 HOLMDEL, NJ 07733-0205

DAS -- DTMF ACCESSORY SQUELCH

DTMF DETECTION AND I/O

FILE: DAS-SCH ENGR: PAUL NEWLAND REV 2

ORIG: 930724 LST MOD: 960402 SHT: 2 OF 3

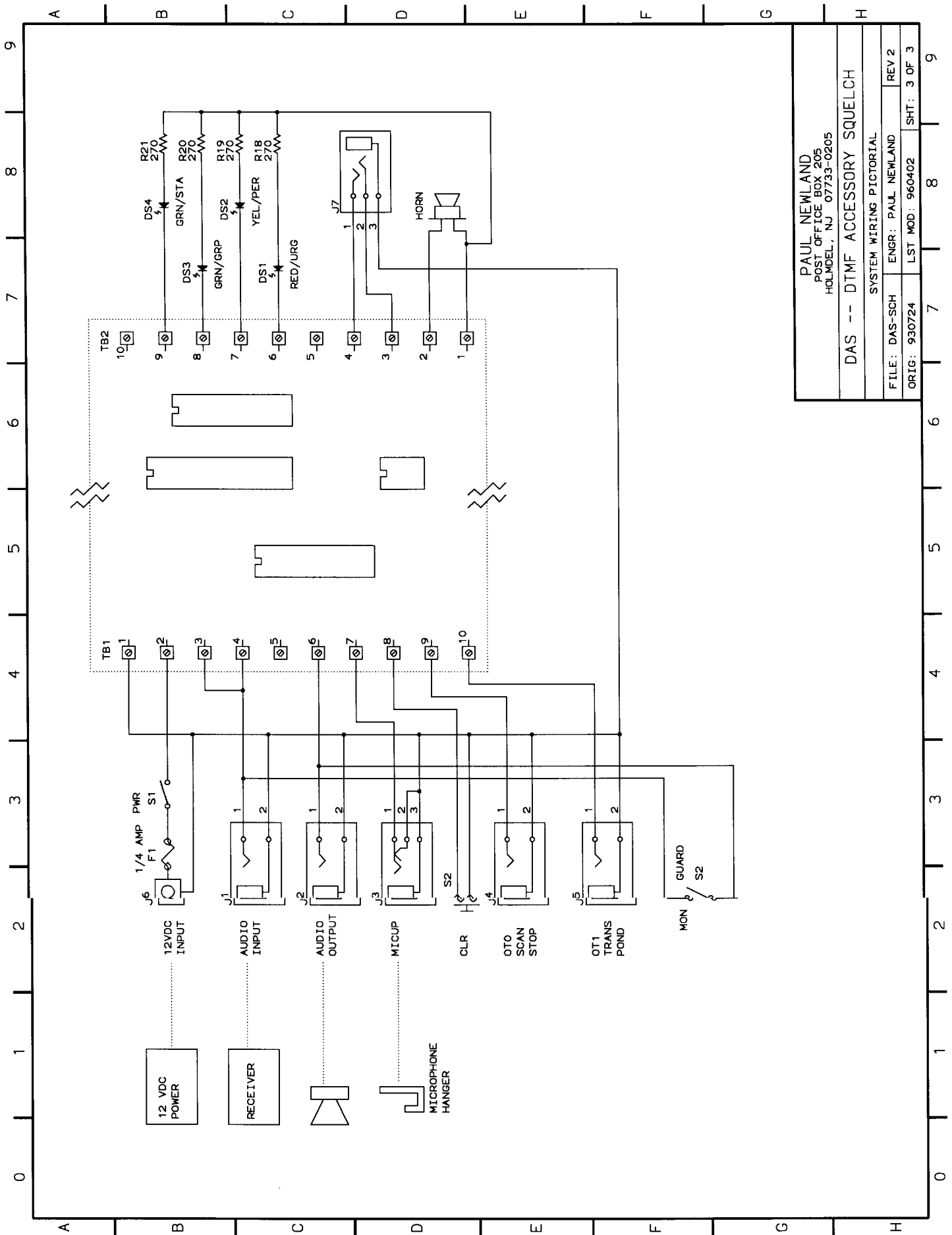

PAUL NEWLAND POST OFFICE BOX 205 HOLMDEL, NJ 07733-0205		
DAS -- DTMF ACCESSORY SQUELCH		
SYSTEM WIRING PICTORIAL		
FILE: DAS-SCH	ENGR: PAUL NEWLAND	REV 2
ORIG: 930724	LST MOD: 960402	SHT: 3 OF 3